

# GRAND GOLDEN LINE G750L / G750GL

- Introduction and Main Features
- Detailed Overview
- Custom Options
- Technical Specifications



## Introducing new G750 model..... another GRAND Masterpiece!



New for 2019, our Golden Line series G750 model is a long-awaited step up from GRAND's highly successful G650.

This new 7.5-meter and Category B\* design offers more space and luxury while retaining the extraordinary sea keeping qualities inherent in the class.

The G750's distinctive contemporary styling and comfort, accompanied by a comprehensive range of options plus outboard motors up to 250 HP gives this new GRAND model a degree of authority and elegance that far surpasses the competition!

## G750 – Introduction and Main Features

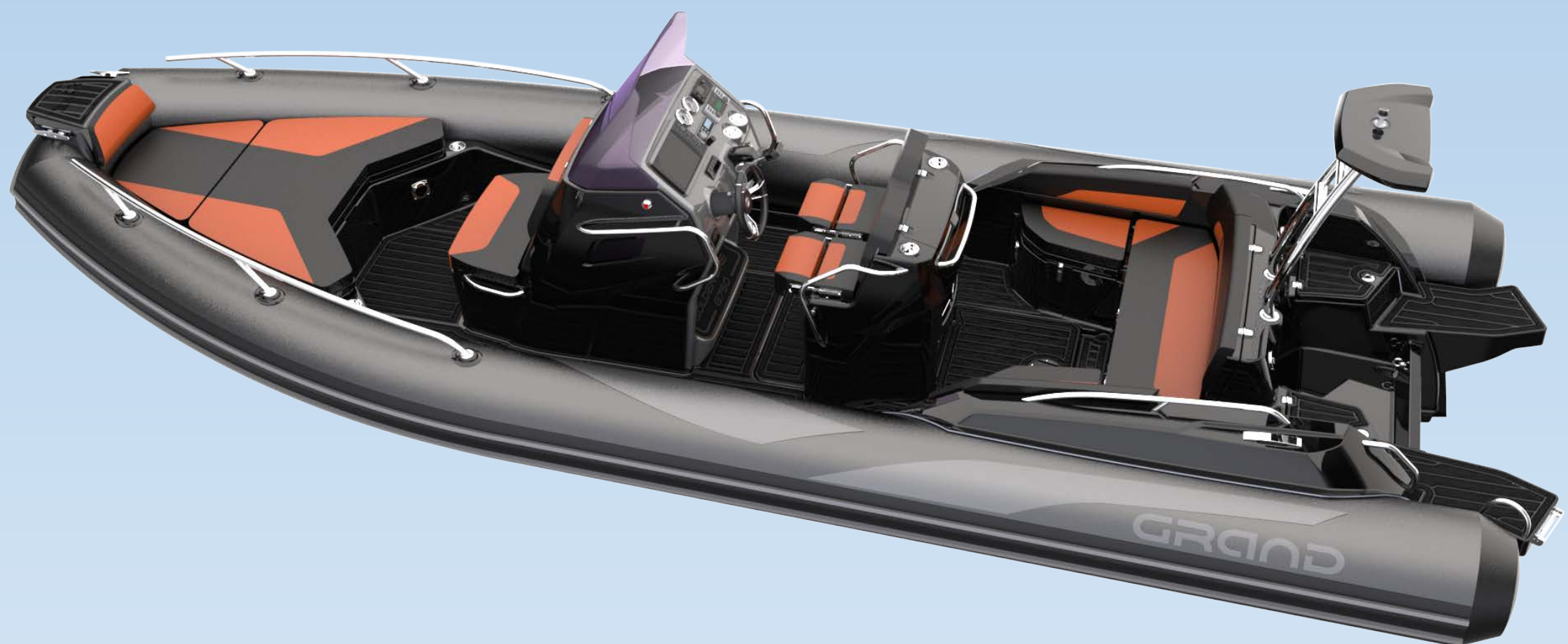

The G750 model completes GRAND's Golden Line Cruiser range fitting neatly between the G650 and G850 models. It offers the optimum balance between a high-performance larger RIB and a sumptuously appointed contemporary family boat. GRAND's proven High Step Deep-V Hull design ensures excellent maneuverability combined with dynamic stability and impressive speed capability.

Inherent within GRAND's well-established Golden Line styling concept the G750 offers:

- GRAND's proven Deep V-hull design
- Dynamic shape contouring with sweeping lines
- Stainless steel bow rails
- A well proportioned deck layout comfortably accommodates up to 10 passengers
- Spacious and expandable bow sundeck
- Newly designed centrally-positioned modern steering console
- A Large capacity, 260-liter centrally positioned built-in fuel tank for extended range trips, outstanding overall seakeeping balance and maneuverability
- U-form rear sofa-style seat with dedicated boarding passageway
- Plenty of storage capacity throughout the boat
- The optional WC is discreetly located inside the steering console superstructure
- An extensive selection of options, including custom color combinations, Hypalon® tubes, SeaDek® flooring, Silvertex® upholstery, waterski mast, and many more ensuring your G750 meets your needs and individuality.

## G750 – Introduction and Main Features

Thanks to its 7.5-meter design and well proportioned deck layout the new G750 RIB can safely and comfortably accommodate up to 10 persons. This is complemented by its spacious and expandable bow sundeck, with the optional additional cushion feature.

As with other established models in the Golden Line series, the gelcoat color, tubes and upholstery are easily customized thanks to a wide selection of available colors. It is also possible to select and custom-order upholstery in various bi-color schemes when using GRAND's 3D Boat Configurator available at [grandboats.com](http://grandboats.com). Thus, the choice of possible color combinations becomes extensive and exciting, making it possible to give your boat a highly personalized and distinctive appearance.

The craft's comfort and safety can be further enhanced by including the optional SeaDek® textured micro-dot flooring for enhanced non-slip characteristics.



## G750 – Detailed Overview

### At the Bow

As a standard Golden Line feature, a traditional bow step plate complete with two mooring cleats is provided. This makes it easy to exit the boat from the bow and a non-slip surface is provided here as an additional safety feature.

A detachable cushion covers the bow step plate on its in-board side completing the already spacious sundeck while aiding your comfort. It is also possible to extend the size of the sundeck even further by adding an extra cushion (optional) and making it a perfect place for sunbathing or just relaxing close to the water.

As with all GRAND RIBs, there is a roomy locker built into the bow seat for storing the anchor, mooring lines and other useful items. Stainless steel bow rails, an elegant and valuable safety feature are included in the G750 standard package. As an option, an electric windlass is available for automatic anchor lifting.

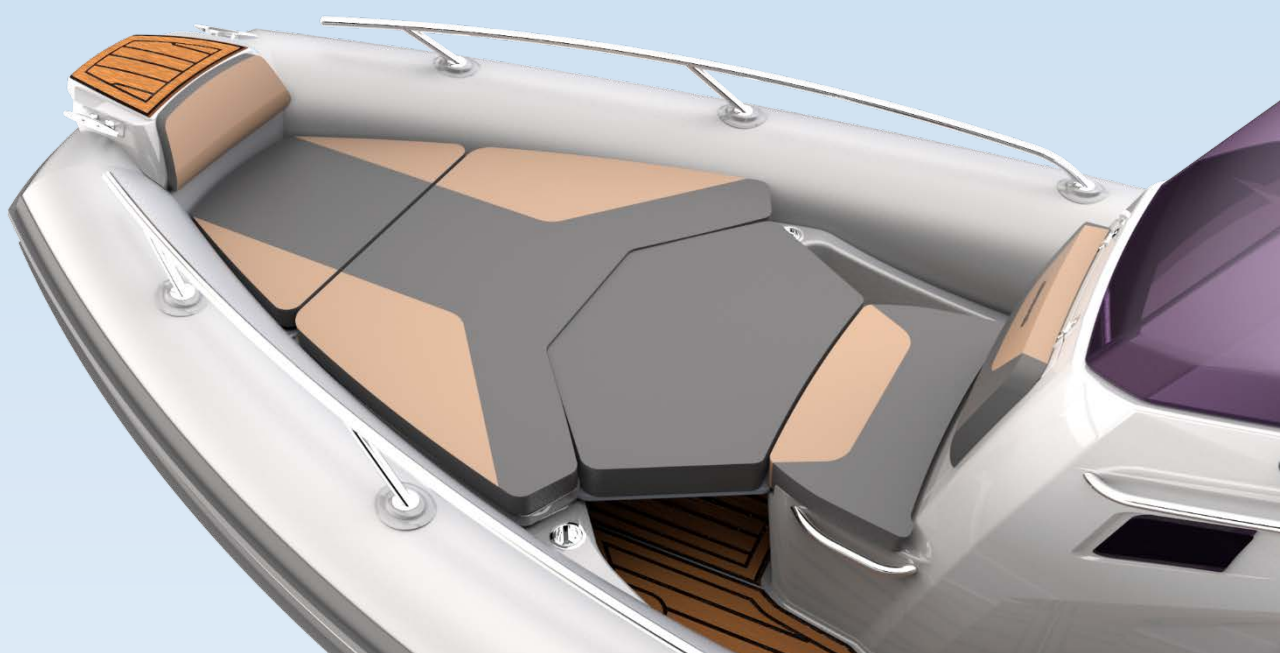

## G750 – Detailed Overview

### Mid-Section



The newly designed steering console is centrally positioned for optimal balance, drivability and sea keeping performance. Two stainless steel safety handrails are installed on each side of the console to support the driver and the passenger.

The G750's up-to-date dashboard layout will accommodate a wide selection of ergonomically positioned standard and optional controls and accessories. There is enough room for all the must-have instruments and accessories, such as a speedometer, tachometer, fuel and temperature gauges, GPS with up to 17" screen, Radar, Audio, USB ports, and other electronics. All these instruments and controls are easily visible thanks to the generously proportioned dashboard and slightly tilted aero/sun screen.

There is also a splash-proof roomy glove compartment and two stainless steel cup holders within immediate reach.

## G750 – Detailed Overview

Mid-Section



The steering console also includes a huge storage space, which is easily accessible via the console's front hatch. This storage space features two side portholes and is large enough to store items such as water skis, wakeboards and fishing gear.

As an option, thanks to its large dimensions it is also possible to accommodate a marine WC. This private and useful facility will be much appreciated and is an amenity not always found in similar class/size RIB competition.

## G750 – Detailed Overview

### Mid-Section

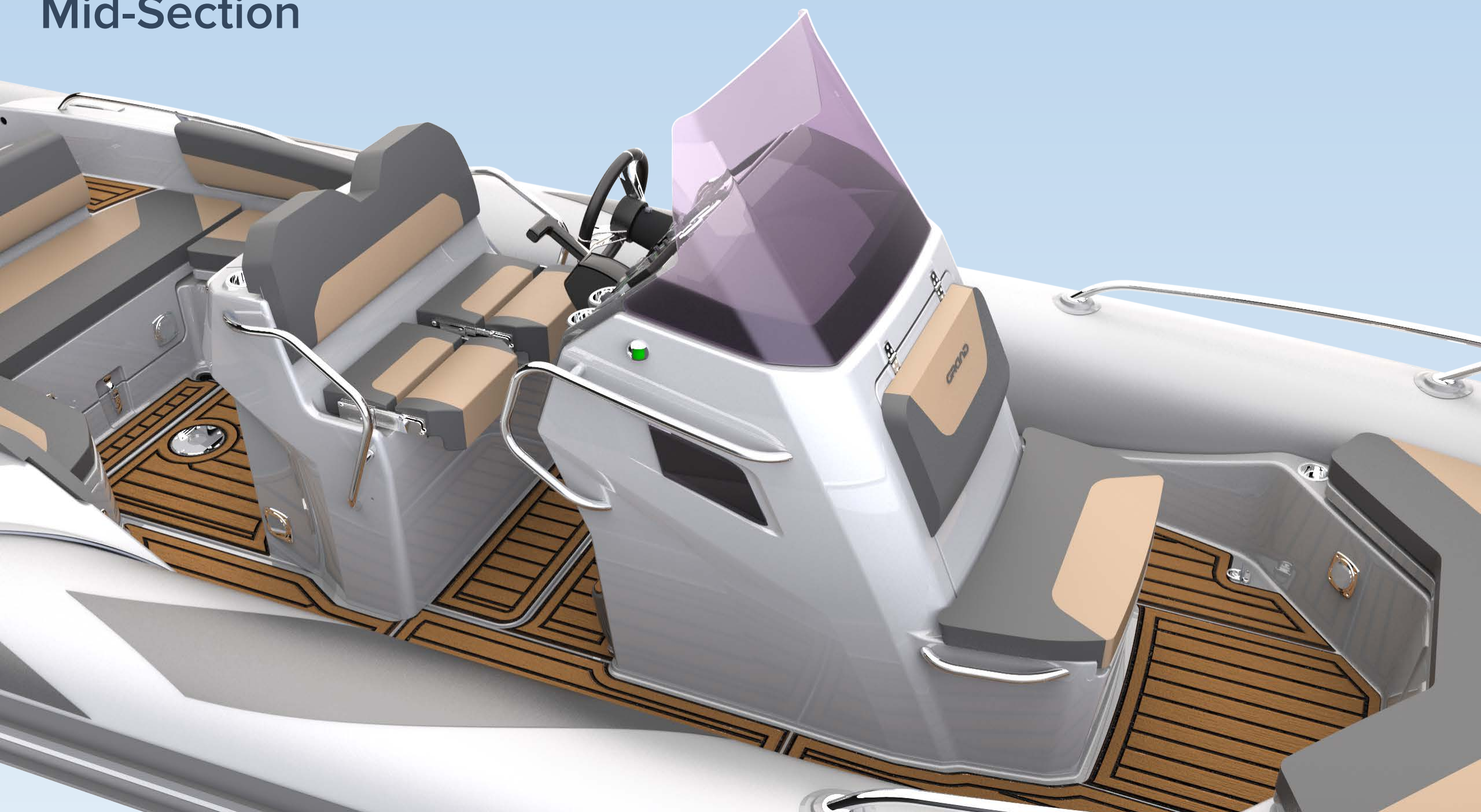

The steering console superstructure is tilted a touch backwards emphasizing the elegance and sporty dynamics of G750 silhouette, while at the same time providing ample space for the pilot and passenger.

Both Driver and Passenger seats are foldable thus providing excellent support when standing or sitting. Two stainless steel handrails are attached to each side of the seating bench, as well as an additional safety hand-bar on the back of the seating console. This helps passengers to move around the craft with ease and confidence.



## G750 – Detailed Overview

Towards the Stern

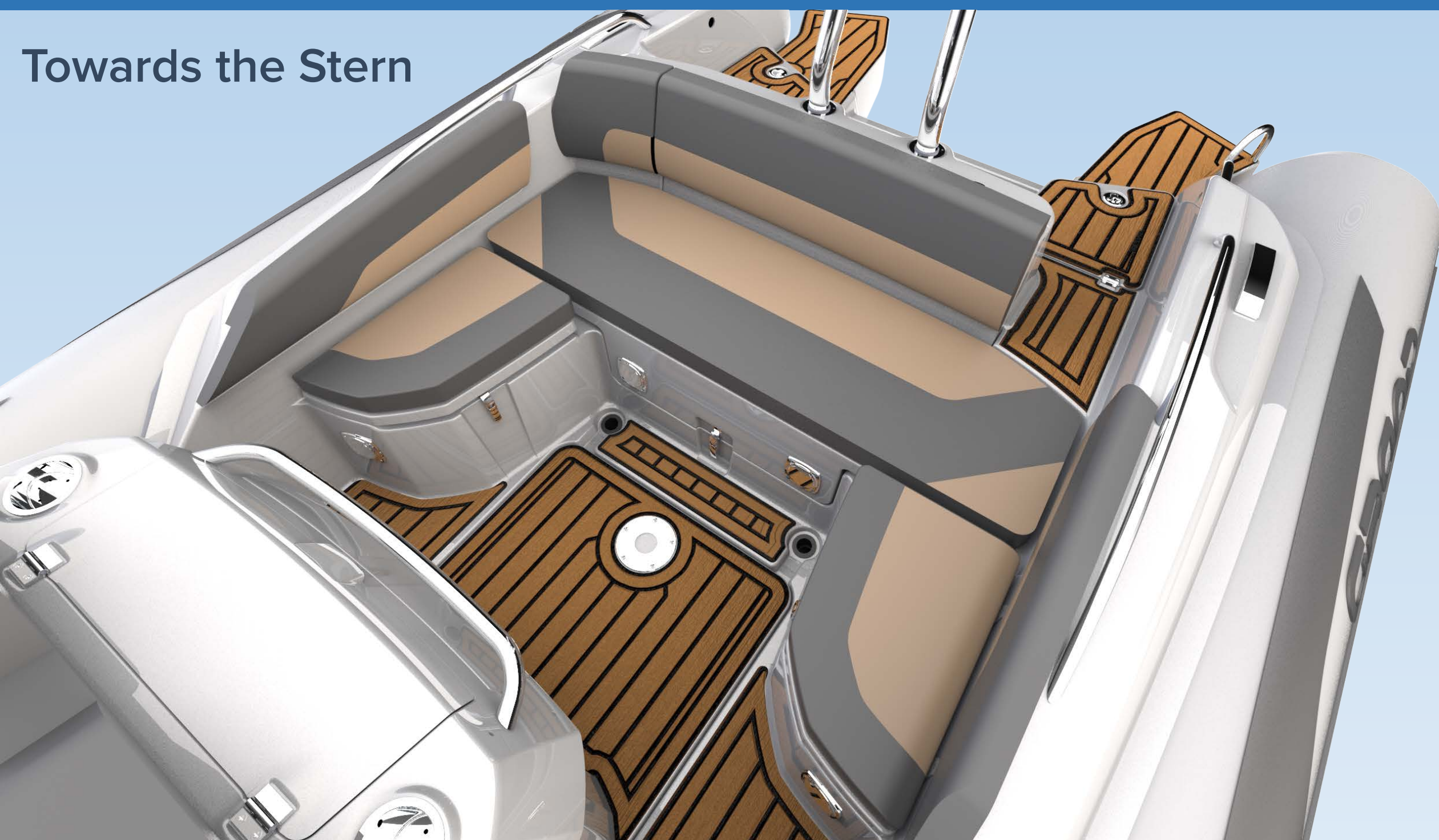

The large area to the rear of the steering console is well thought out and organized. As in all GRAND Golden Line RIBS, there is a generous amount of storage space aft comprising: three roomy lockers under the U-form rear seat, as well as two dedicated rear rope/anchor hatches at the stern.

The U-form rear sofa-style seat features a dedicated boarding passageway for easier access from the water via the built-in folding ladder. The same opening also becomes very useful when it comes to putting on water skis.

## G750 – Detailed Overview

Towards the Stern

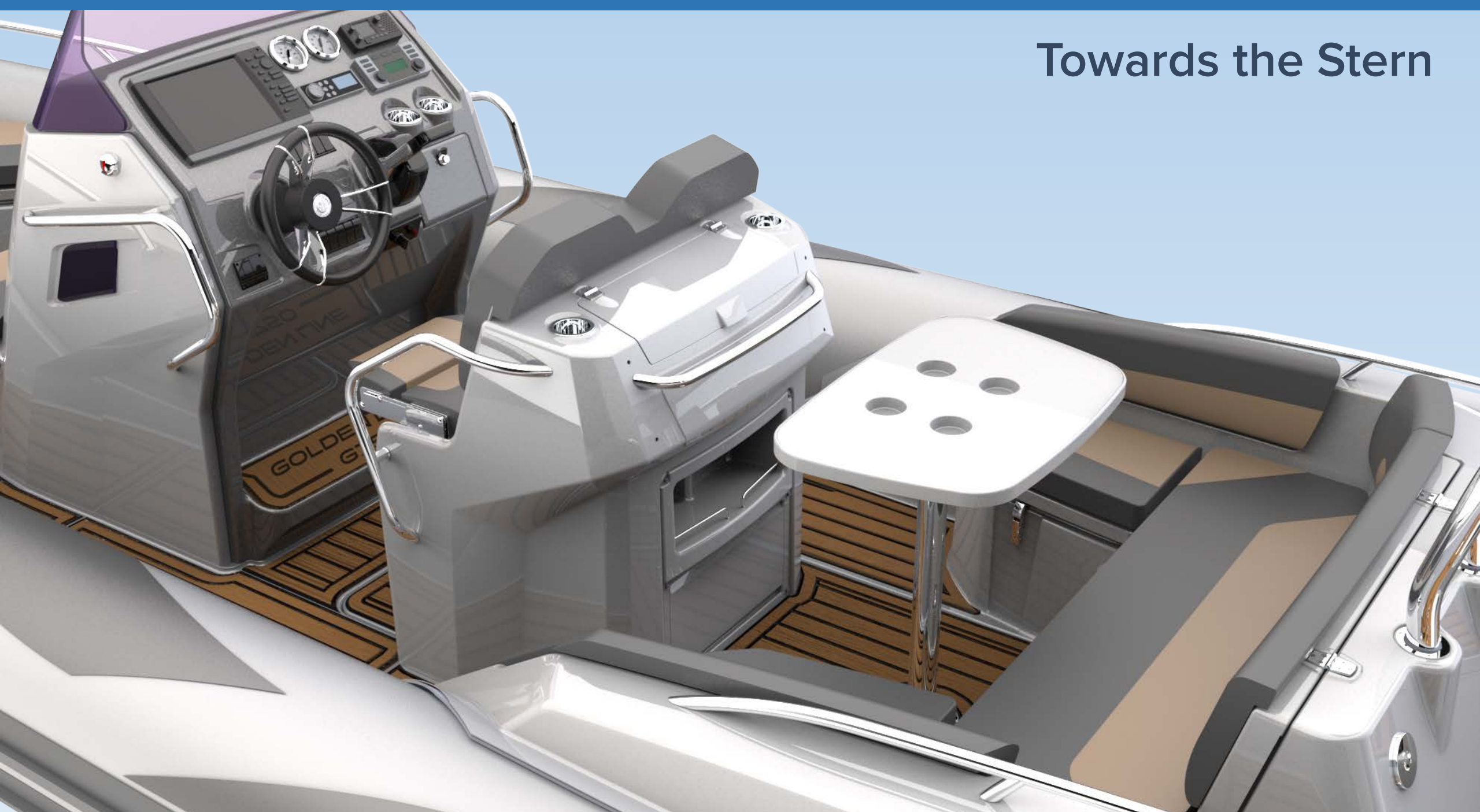

The rear side of the Driver/Passenger seating bench offers another multipurpose storage compartment at the top of which can be fitted an optional sink and fittings for a water shower set.

Moreover, there is a storage shelf for drinking cups, and yet another compartment where an optional cooling drawer can be installed.



## G750 – Detailed Overview

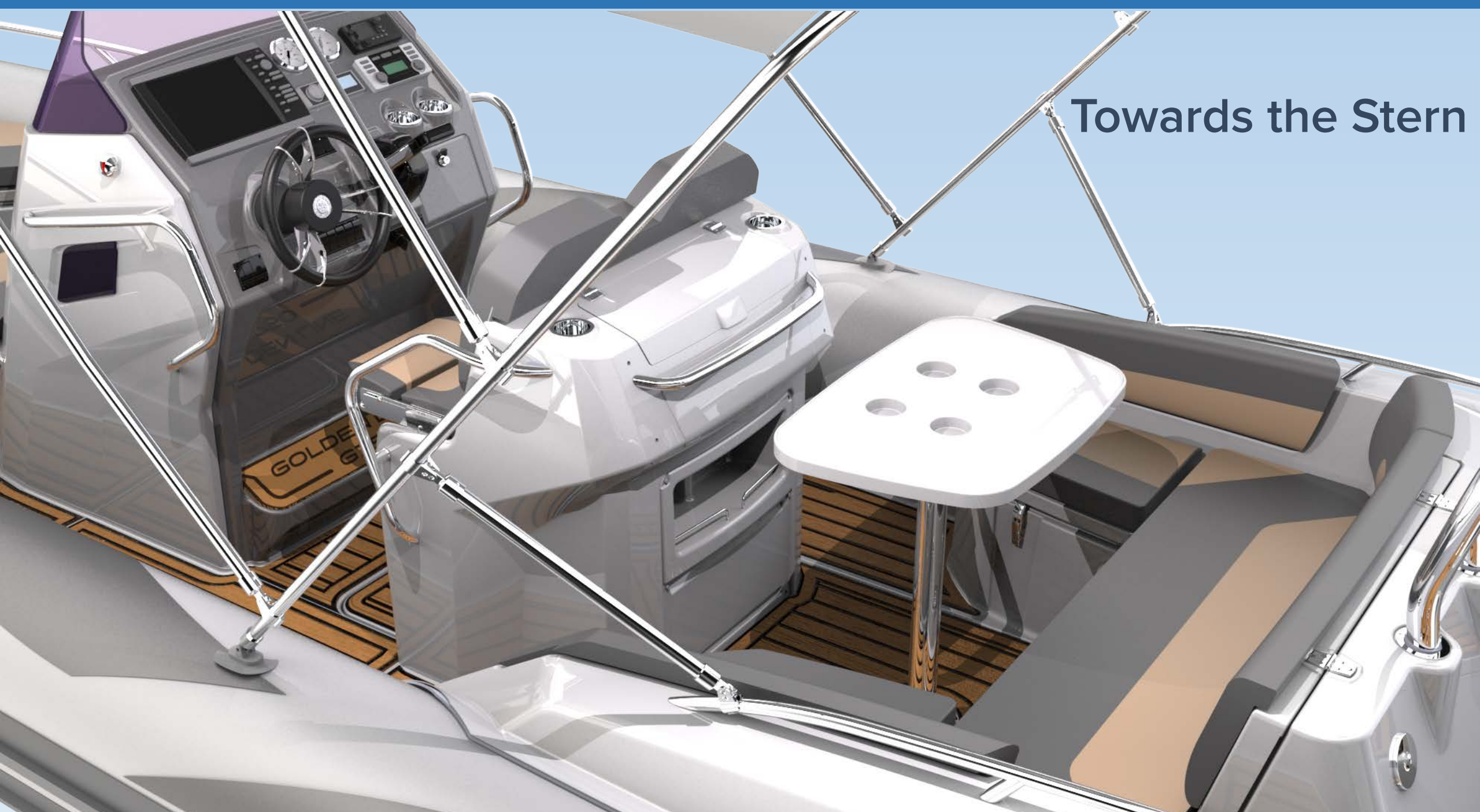

As a welcoming touch, the aft space easily transforms into a cozy and intimate dining area when the optional removable table and Bimini are fitted. Alternatively, the U-form rear seat can be extended with an additional cushion making it another sun deck.



## G750 – Detailed Overview

### Towards the Stern

A water ski towing mast with GRP top is also available for those who enjoy water skiing and wake boarding.

A pair of integrated stylish yet very practical swimming platforms accompanied by stainless steel safety handrails and a foldable ladder complete the G750's elegant stern layout.



## G750 – Custom Options

### Color Options

Our traditional standard colors are gray tubes, white GRP and gray upholstery. As with other models in the series, a range of colors is available for the GRP and tubes.

Upholstery can also be selected from a wide range and ordered in different bicolor combinations. This provides for a diverse range of color combinations and the opportunity to give your boat a highly personalized appearance.

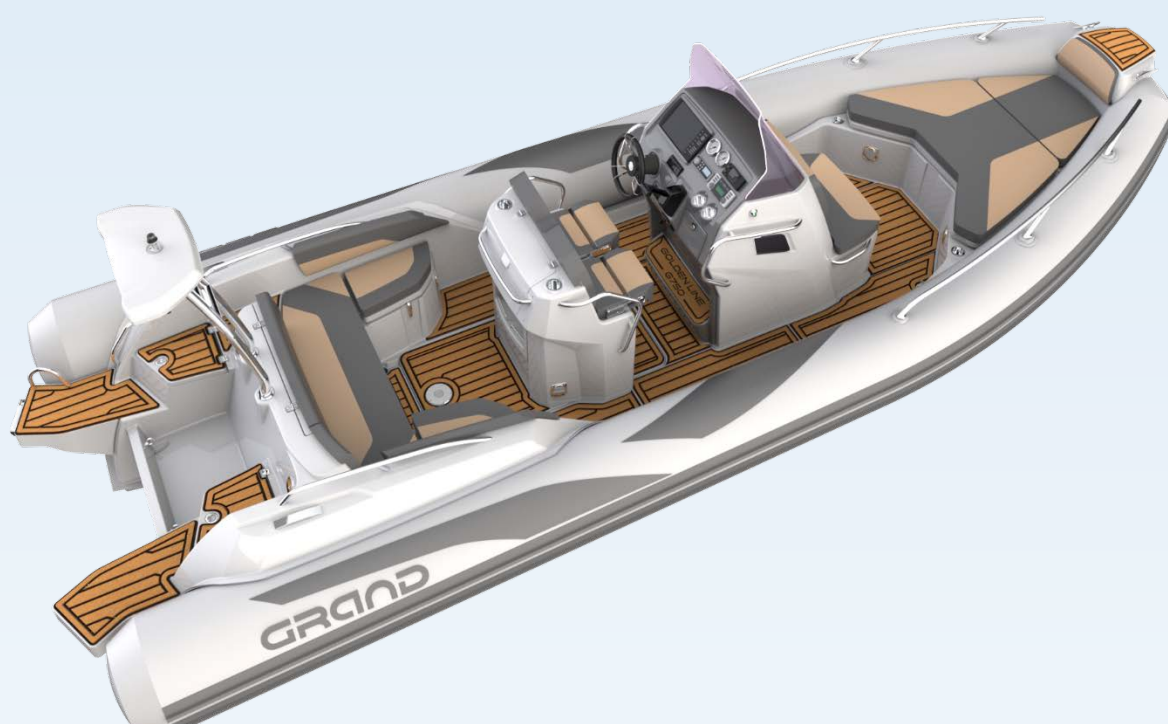

## G750 – Custom Options

### Optional Equipment List

- Bow and rear extended sundecks
- Water shower set and 75-lit tank
- Waterski towing arch with towing eye and GRP top
- Removable table with 4 cup holders
- Marine WC
- Hydraulic steering system
- Steering wheel PERFORMANCE (black)
- Stainless steel bimini top
- Overall cover, consoles and rear seat covers
- Two overpressure valves
- Keel and tube protector packages
- SILVERTEX upholstery upgrade
- SeaDek antiskid set

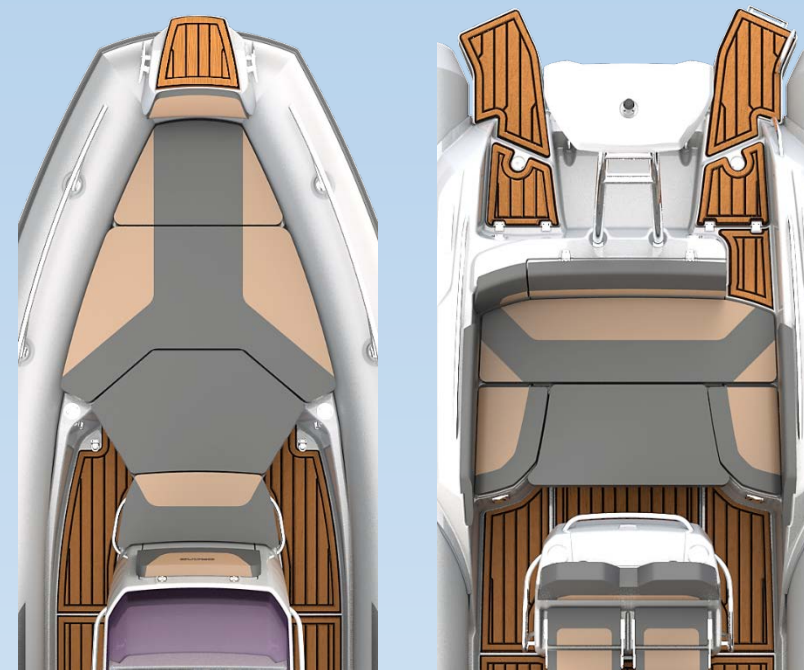

## G750 – SUMMARY



During the design stage of the G750 we introduced many unique engineering and design ideas in order to make this boat an instant success.

No matter where this RIB takes you – we are sure our G750 will delight you with its superb performance and safety, excellent sea-keeping qualities, renowned craftsmanship, beautiful looks and superior comfort.

The Golden Line family of boats is now further enhanced with the introduction of the G750, a craft which incorporates years of solid expertise in designing and building top performing, stylish luxury RIBs - another GRAND Masterpiece!

# G750 – Technical Specifications

Length overall	cm	750
	ft/inches	24'6"
Length internal	cm	557
	ft/inches	18'3"
Width overall	cm	285
	ft/inches	9'4"
Width internal	cm	170
	ft/inches	5' 58"
Tube diameter	cm	58
	ft/inches	22"
Bare boat weight *	kg	950
	lbs	2094
Transport gross weight **	kg	1250
	lbs	2756
Loading capacity ***	kg	1300
	lbs	2866
Passenger capacity	number	10
No of chambers	number	5
Engine recommended	HP	200
	kW	150
Engine max ***	HP	250
	kW	184
Engine weight max	kg	285
	lbs	628
Engine shaft length	cm/inches	63,5 / 25"
Midsection / aft deadrise	Degrees / inches	25° / 20"
Stowed dimensions of package N°1	cm	745
	cm	214
	cm	127
	ft/inches	24'4"
	ft/inches	7'0"
	ft/inches	7'1"
Stowed dimensions of package N°2	cm	157
	cm	140
	cm	119
	ft/inches	5'2"
	ft/inches	4'6"
	ft/inches	3'9"
Stowed dimensions of package N°3	cm	120
	cm	131
	cm	82
	ft/inches	3'9"
	ft/inches	4'3"
	ft/inches	2'7"
Hull type		RIB
Boat design category****		B

\* – The bare boat weight is just a weight of the empty boat without any removable accessories.

\*\* – The transport gross weight is the weight of the complete boat in standard package.

\*\*\* – Because of differences in local boat-building standards, the Loading capacity and Maximum Engine Power may vary by country. Please check that with your local GRAND dealer.

\*\*\*\* – Boat design category under European Union Directive 2013/53/EU.